



ISSN: 0976-3031

Available Online at <http://www.recentscientific.com>

International Journal of Recent Scientific Research
Vol. 8, Issue, 3, pp. 15930-15932, March, 2017

**International Journal of
Recent Scientific
Research**

Research Article

AUTOMATIC SOIL MOISTURE AND TEMPERATURE DETECTOR

Mithilesh A.Thaker., Ronak H.Bhanderi and Bhavin B.Markana

Electronics & Telecommunication Kjsieit Mumbai, India

DOI: <http://dx.doi.org/10.24327/ijrsr.2017.0803.0036>

ARTICLE INFO

Article History:

Received 15th December, 2016

Received in revised form 25th

January, 2017

Accepted 28th February, 2017

Published online 28th March, 2017

ABSTRACT

In the past couple of decades, there is rapid growth in terms of technology in the field of agriculture. Different monitoring and controlled systems are installed in order to increase the yield. The yield rate may decrease due to numerous factors. Irregular irrigation or excess irrigation is one of the key factors that cause the degradation of yield. So the developed monitoring system mainly focuses on predicting the soil moisture as well as surrounding temperature suitable to crop. The developed system nearly predicts the start of change in soil moisture and temperature.

Key Words:

Agriculture; yield; irregular irrigation; monitoring;

Copyright © Mithilesh A Thaker et al, 2017, this is an open-access article distributed under the terms of the Creative Commons Attribution License, which permits unrestricted use, distribution and reproduction in any medium, provided the original work is properly cited.

INTRODUCTION

The project is designed to develop an automatic irrigation system that switches a pump motor on/off upon sensing moisture content of the soil. In the field of agriculture, use of proper method of irrigation is important. The advantage of using this method is to reduce human intervention and still ensure proper irrigation. The project uses a PIC series microcontroller which is programmed to receive input signal of varying moisture condition of the soil through a sensing arrangement. This is achieved by using an op-amp as comparator which acts as interface between the sensing arrangement and the microcontroller. Once the controller receives this signal, it generates an output that drives a relay for operating the water pump. An LCD display is also interfaced to the microcontroller to display the status of the soil and water pump. The sensing arrangement is made by using two stiff metallic rods or the sensor provided to be inserted into the ground field under control. Connections from the same are interfaced to the control unit. By integrating GSM technology such that whenever the water pump switches ON/OFF, delivered to the concerned person regarding the status of the pump. We can also control the pump through SMS.

Different monitoring system in agriculture

Field of agriculture has seen the rapid advancement in terms of technology from past couple of decades. Farmers start to utilize

various monitoring and controlled system in order to increase the yield. Different agricultural parameters like temperature, relative humidity, soil moisture, carbon dioxide, light detection, soil pH, etc. are monitored as well as controlled. Here it is review of some of these monitoring systems which can help the farmers to improve the yield.

In one of the systems, Wi-Fi module is used for wireless communication. The system used Atmega controller. It mainly focuses on transmitting different environment conditions to selected server via routers. One other system with same controller, monitored temperature and water usage. The realtime values are transmitted wirelessly to the substation using ZigBee. Substation performs the controlling action on motor and irrigation valve according to preset value of moisture as set by the farmers.

Environment inside polyhouse was controlled using programmable interface controller (PIC). The system has set some references like Tmin, Tmax and Rhmin. Once these references are violated then controller would command to relay operating circuitry for proper controlling action. An irrigation management model for higher crop yield was presented. This model is based on estimation of soil water tension (SWT). PIC would modify the irrigation scheduling based on this SWT value. Bluetooth and GSM based remote monitoring and control system is proposed using PIC. Abnormal conditions across the field are informed to farmers via SMS and then farmer can take appropriate controlling

*Corresponding author: **Mithilesh A Thaker**

Electronics & Telecommunication Kjsieit Mumbai, India

System Development

System consists of Sensing unit, LCD, buzzer, relay Max 232 and PIC-controller. Sensing unit read the different atmospheric conditions. It consists of temperature sensor, soil moisture sensor. The readings are given to microcontroller (PIC 16F877A). Microcontroller will display these reading on LCD as well as transmit it through wired network. Block diagram of transmitter is as shown in Figure 1. Here, in the figure, all the sensors are interfaced to microcontroller. Microcontroller will drive the buzzer if needed and different values will be displayed on LCD

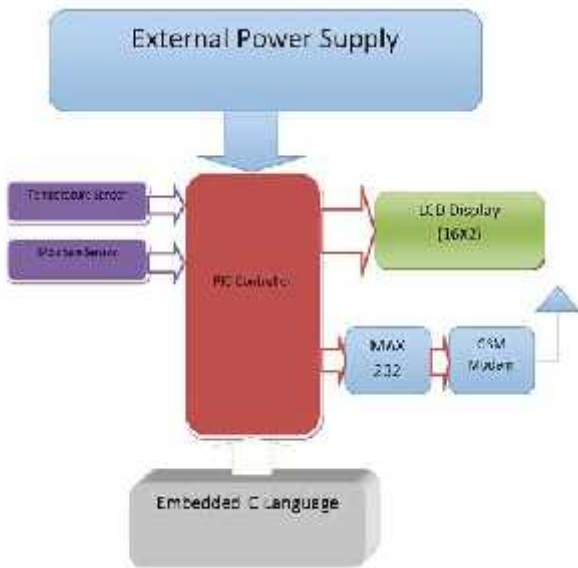

Fig. 1 Methodlogy diagram

Temperature Sensor

The LM35 series are precision integrated-circuit temperature sensors, whose output voltage is linearly proportional to the Celsius (Centigrade) temperature. The LM35 thus has an advantage over linear temperature sensors calibrated in ° Kelvin, as the user is not required to subtract a large constant voltage from its output to obtain convenient Centigrade scaling. The LM35 does not require any external calibration or trimming to provide typical accuracies of $\pm 1/4^{\circ}\text{C}$ at room temperature and $\pm 3/4^{\circ}\text{C}$ over a full -55 to $+150^{\circ}\text{C}$ temperature range. Low cost is assured by trimming and calibration at the wafer level.



Fig 2 LM35 Temperature sensor

The LM35 low output impedance, linear output, and precise inherent calibration make interfacing to readout or control circuitry especially easy. It can be used with single power

supplies, or with plus and minus supplies. As it draws only $60 \mu\text{A}$ from its supply, it has very low self-heating, less than 0.1°C in still air. The LM35D is rated to operate over a 0° to $+100^{\circ}\text{C}$ temperature range.

Moisture Sensor

The sensor measures the dielectric constant of the soil in order to find its volumetric water content (VWC). It obtains volumetric water content by measuring the dielectric constant of the media through the utilization of frequency domain technology. Since the dielectric constant of water is much higher than that of air or soil minerals, the dielectric constant of the soil is a sensitive measure of volumetric water content. The sensor has a low power requirement and very high resolution. This gives the ability to make many measurements (i.e. hourly) over a long period of time with minimal battery usage. In addition, the sensors incorporate a high frequency oscillation, which allows the sensor to accurately measure soil moisture in any soil with minimal salinity and textural effects.

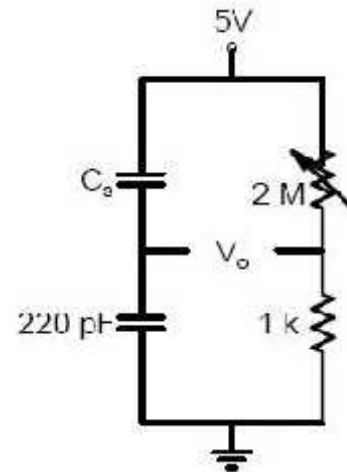

Fig.3 Moisture sensor

PIC 16F877A

The microcontroller to be used in the project is PIC16F877 from Microchip family. There are numerous reasons behind selecting this microcontroller. It has 14 bit core, 40 pin DIP, works on up to 20 MHz It also has flash memory for rewritable purpose. This microcontroller is very easy to be assembled, program and also the price is very cheap. The erasing time is almost unnoticeable because once new program are loaded into the PIC, the old program will automatically be erased immediately. PIC16F877A already made with 368 bytes of Random Access Memory (RAM) inside it. Any temporary variables that are used inside the program are stored inside the RAM thus eliminating the need of external memory. The size of program code that can be stored is about 8k words inside PIC16F877A ROM. 1 word size is 14 bits which is more than enough for the system. The crystal oscillator speed that can be state the units for each quantity that you use in an equation.

Now the two sensors will read the environmental condition across the farm and is sent via. Unit. Receiver has the same wireless unit as that of the transmitter it will display the real time values of the environmental condition

Performance Analysis

Soil Moisture Sensor before one arm i.e. two aluminum plates of self made bridge is placed at a distance of 15 cm from the earth surface. The distance between the plates was 3 cm. Then slowly the moisture content of the soil is increased from dry to saturated one. The same procedure is carried out for three different temperatures at T = 32°C, 37°C, 44°C and the result obtained is as shown in graphical form in Figure 8. Moisture sensor nearly shows same voltage range at three different temperatures. Thus it indicates the stability of the self made moisture sensor. It shows 0.5 mV change in voltage for 10 % moisture change.

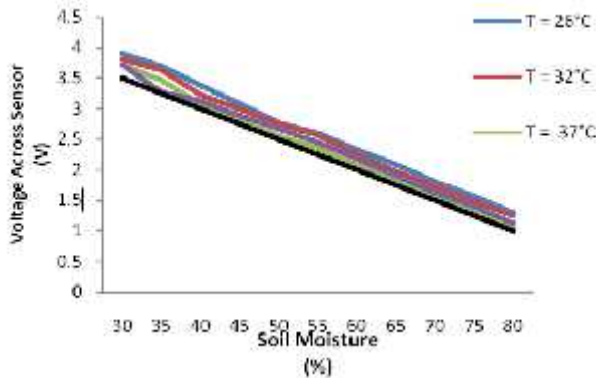

Fig.4 Variation in soil moisture at different temperature

Operation

The project is designed to develop an automatic irrigation system that switches a pump motor on/off upon sensing moisture content of the soil. In the field of agriculture, use of proper method of irrigation is important. The advantage of using this method is to reduce human intervention and still ensure proper irrigation. The project uses a PIC series microcontroller which is programmed to receive input signal of varying moisture condition of the soil through a sensing arrangement. This is achieved by using an op-amp as comparator which acts as interface between the sensing arrangement and the microcontroller. Once the controller receives this signal, it generates an output that drives a relay for operating the water pump. An LCD display is also interfaced to the microcontroller to display the status of the soil and water pump. The sensing arrangement is made by using two stiff metallic rods or the sensor provided to be inserted into the ground field under control. Connections from the same are interfaced to the control unit.

Table 1 Expected results

Transmitted data	Received data	Transmitted data	Received data	Distance between Tx and Rx (meter)
Moisture (%)	Moisture (%)	Temp. °C	Temp. °C	
07	07	28	28	05
07	07	30	30	05
07	07	32	32	05

CONCLUSION

The developed system is Simple and cost effective than most other systems present in the market. It measures different environmental conditions. It includes measurement of atmospheric temperature, soil temperature, etc. System uses wireless module for the data transfer, communication purpose. So it can be use in open fields as well as inside greenhouse as the range of wireless module is up to 25m with / without different obstacles like trees, benches, walls, cupboard, magnet, etc. With the use of wireless module, system becomes flexible, robust, etc. Sensors can be placed anywhere in the field and if there is need of relocation then it can be easily done. System is also tested for different temperature and it is found that all the sensors work with minimum deviation in output. With the use of drip irrigation, water is provided directly to the roots of the crop. Thus wastage of water is minimized and water resources are optimized to obtain better crop yield. This system is advantageous to farmers as it not only saves water but also helps farmers in fighting the diseases. Thus it will increase the yield of the crop.

Reference

MahirDursun and SemihOzden, A wireless application of drip irrigation automation supported by soil moisture sensors, Scientific Research and Essays Vol. 6(7), pp. 1573-1582, 4 April, 2011

Gracon H. E. L. de Lima, Lenardo C. e Silva, Pedro F. R. NetoMestradoemCiñncia da Computao, WSN as a Tool for Supporting Agriculture in the Precision Irrigation, 2010 Sixth International Conference on Networking and Services, pp.137- 142, 2010

K.Prathyusha1, M. Chaitanya Suman2, Design of embedded systems for the automation of drip irrigation, IJAIEM Volume 1, Issue 2, October 2012

How to cite this article:

Mithilesh A Thaker *et al.*2017, Automatic Soil Moisture And Temperature Detector. *Int J Recent Sci Res.* 8(3), pp. 15930-15932.