



*International Journal Of*  
**Recent Scientific  
Research**

ISSN: 0976-3031  
Volume: 7(4) April -2016

DIMENSIONAL CALCULATIONS OF MUFF COUPLING BY USING C-PROGRAMMING

Rohan R Ozarkar, Nitin G Shinde and Manish S Sathe



THE OFFICIAL PUBLICATION OF  
INTERNATIONAL JOURNAL OF RECENT SCIENTIFIC RESEARCH (IJRSR)  
<http://www.recentscientific.com/> [recentscientific@gmail.com](mailto:recentscientific@gmail.com)

**Research Article****DIMENSIONAL CALCULATIONS OF MUFF COUPLING BY USING C-PROGRAMMING****Rohan R Ozarkar<sup>1\*</sup>, Nitin G Shinde<sup>2</sup> and Manish S Sathe<sup>3</sup>**<sup>1,2,3</sup> Department of Mechanical Engineering, R. C. Patel Institute of Technology Shirpur, Maharashtra, India**ARTICLE INFO****Article History:**Received 05<sup>th</sup> January, 2016  
Received in revised form 21<sup>st</sup>  
February, 2016  
Accepted 06<sup>th</sup> March, 2016  
Published online 28<sup>th</sup>  
April, 2016**Keywords:**C-Programming, Muff Coupling,  
Sleeve Coupling**ABSTRACT**

C-language has become one of the most widely used programming languages of all time. It is useful for many applications that had formerly been coded in assembly language. The knowledge of computer programming in C is one of the most fundamental skills for today's students. In this paper the C-language is utilized to do the calculations of various dimensions related to the design of Muff (Sleeve) coupling by using some input parameters. With the conventional method first the design process was finalized then its flow chart was prepared followed by the coding. With the help of one sample design illustration the output is compared with physical calculations.

Copyright © Rohan R Ozarkar, Nitin G Shinde and Manish S Sathe., 2016, this is an open-access article distributed under the terms of the Creative Commons Attribution License, which permits unrestricted use, distribution and reproduction in any medium, provided the original work is properly cited.

**INTRODUCTION****C Programming**

C is a general-purpose, high-level language that was originally developed by Dennis M. Ritchie. C has now become a widely used professional language for various reasons like ease in learning, structured language, efficient programs, handling of low-level activities and its ability to be compiled on a variety of computer platforms. A C program basically consists of the preprocessor commands, functions, variables, statements, expressions and comments. First the coding is done then code of the program is converted to an executable binary image using compiler [3].

**Muff Coupling**

Couplings are the devices which are used to connect the shafts which are normally coaxial with slight or no misalignment. In engineering applications there arise several cases where two shafts have to be connected so that power from driving shaft is transmitted to driven shaft without any change of speed. Several types of couplings are used in practice. Muff or sleeve coupling is the simplest form of a coupling.

It consist a steel or cast iron sleeve fitted on the ends of shaft to be connected. The sleeve is connected to the shaft by means of keys. Muff coupling has the features like simplicity of construction due to very few components, ease in assembly and

dismantling, simple and easy to maintain as their high torque capabilities make them suitable for higher rpm power transmission applications, no lubrication is required due to rigid connection, low operational cost as no lubrication is required and maintenance is minimal, operational cost is very low and smooth and quiet operation due to no moving parts and thus noiseless operation. [1].

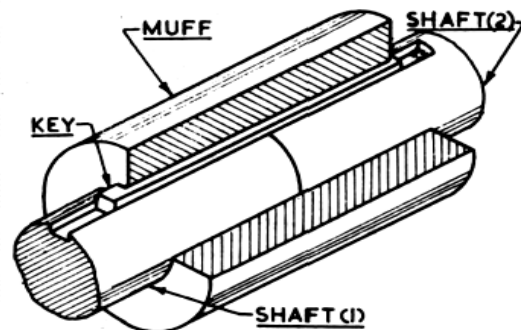

Figure 1 Muff coupling [2]

**DESIGN OF MUFF COUPLING****Design for shaft**

Let  $d$  = diameter of the shaft,  
As we know that the torque transmitted by shaft, key and muff,

\*Corresponding author: **Rohan R Ozarkar**

$$\text{Torque (T)} = \frac{60 \times \text{Power (P)}}{2 \pi \text{ Speed (N)}}$$

We also know that the torque transmitted,

$$\text{Torque (T)} = \frac{\pi}{16} \times \text{Allowable Shear Stress } (\tau_s) \times \text{Diameter of Shaft } (d)^3$$

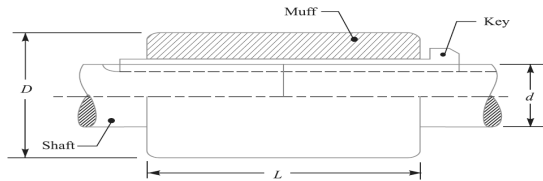

Figure 2 Parts of Muff coupling [4]

### Design for muff (sleeve)

The muff is designed by considering it as a hollow shaft. The usual proportions of cast iron muff are as follows:

Outer diameter of sleeve  $D = 2d + 13$   
 Length of sleeve  $L = 3.5 d$

We know that the torque transmitted by the hollow shaft,

$$\text{Torque (T)} = \frac{\pi}{16} \times \text{Resulting Shear Stress } (\tau_r) \times \frac{D^4 - d^4}{D}$$

If  $\tau_r < \tau_s$  then the design of muff coupling is safe.

### Design for key

The width and the thickness of coupling key are obtained from the proportions. The length of the coupling key is atleast equal to the length of sleeve. The coupling key is usually are made into two parts so that the length of the key in each shaft.

$$l = \frac{L}{2} = \frac{3.5 d}{2}$$

The width (W) and thickness (t) of key can also be taken from the proportion,

$$w = t = \frac{d}{4}$$

The induced crushing and shearing stresses may be checked as follows.

We know that the torque transmitted, Considering shearing of the key,

$$\text{Torque (T)} = \text{length (l)} \times \text{width (w)} \times \text{Resulting Shear Stress } (\tau_{sr}) \times \frac{d}{2}$$

Considering crushing of the key,

$$\text{Torque (T)} = \text{length (l)} \times \frac{\text{thickness (t)}}{2} \times \text{Resulting Crushing Stress } (\sigma_{sr}) \times \frac{d}{2}$$

### FLOWCHART FOR DESIGN

Flow chart is prepared taking help of drawing tool [6].

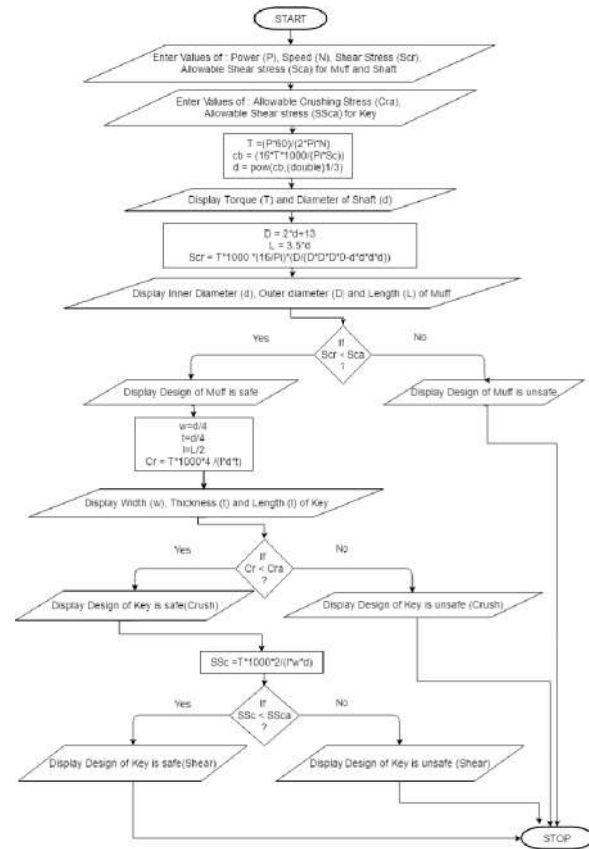

Figure 3 Flow chart for design

### C PROGRAM

Program is written with Notepad++ as shown in Figure 4 and executed on Turbo C compiler.

Source code [7] is given below.

/// Program for Design of Muff Coupling

```
#include<stdio.h>
#include<conio.h>
#include<math.h>
#define Pi 3.141593
void main()
{
    int d;
    float P,N,Sc,Sca,Scr,T,D,L,cb,w,t,l, Cr,Cra,SSc,SSca;
    clrscr();
    printf ("\nFor Muff\nPower(Watt)=\nSpeed(rpm)=\nShear Stress(MPa)=\nAllowable Shear stress(MPa)=\n");
    scanf ("%f%f%f%f",&P,&N,&Sc,&Sca);
    printf ("\nFor Key \nAllowable Crushing Stress(MPa)=\nAllowable Shear stress(MPa)=\n");
    scanf ("%f%f",&Cra,&SSca);
    ///Design of shaft
    T=(P*60)/(2*Pi*N);
    cb=(16*T*1000/(Pi*Sc));
    d=pow(cb,(double)1/3);
    d+=1;
    printf ("\nParameters of Shaft are:\nTorque= %0.2f(N.m)\nDiameter of Shaft= %d(mm)",T,d);
    ///Design of Muff (Sleeve)
```

```

D = 2*d+13;
L = 3.5*d;
printf("\nDimension of Muff:\n\tInner Diameter =
%d(mm)\n\tOuter Diameter= %0.2f(mm)\n\tLength of muff=
%0.2f(mm)",d,D,L);
Scr = T*1000 *(16/Pi)*(D/(D*D*D*D-d*d*d*d));
if (Scr<Sca)
{printf("\n\tDesign of Muff is safe");
}
///Design of Key
w=d/4;
t=d/4;
l=L/2;
printf("\nDimensions of Square Sunk Key:\n\tWidth=
%0.2f(mm)\n\tThickness= %0.2f(mm)\n\tLength=
%0.2f(mm)",w,t,l);
Cr = T*1000*4 /(l*d*t);
if (Cr<Cra)
{printf("\n\tDesign of Key is safe against crushing");
SSc =T* 1000*2/(l*w*d);
if (SSc<SSca)
{printf("\n\tDesign of Key is safe against Shear");
}
else
printf("\n\tDesign of Key is Unsafe against Shear");
}
else
printf("\n\tDesign of Key is Unsafe against crushing");
}
else
printf("\n\tDesign of Muff is Unsafe");
getch();
}

```

**Sample Illustration**

Design a muff coupling which is used to connect two steel shafts transmitting 40 kW at 350 rpm. The material for the shafts and key is plain carbon steel for which allowable shear and crushing stresses may be taken as 40 MPa and 80 MPa respectively. The material for the muff is cast iron for which the allowable shear stress may be assumed as 15 Mpa [5].

**Output**

After execution of program we got output as follows. Figure 5 indicating the screen showing the output.

```

For Muff
Power(Watt)=
Speed(rpm)=
Shear Stress(MPa)=
Allowable Shear stress(MPa)=
40000
350
40
15
For Key
Allowable Crushing Stress(MPa)=
Allowable Shear stress(MPa)=
80
40
Parameters of Shaft are:
Torque= 1091.35(N.m)
Diameter of Shaft= 52(mm)

```

Dimension of Muff:  
 Inner Diameter = 52(mm)  
 Outer Diameter= 117.00(mm)  
 Length of muff= 182.00(mm)  
 Design of Muff is safe  
 Dimensions of Square Sunk Key:  
 Width= 13.00(mm)  
 Thickness= 13.00(mm)  
 Length= 91.00(mm)  
 Design of Key is safe against crushing  
 Design of Key is safe against Shear

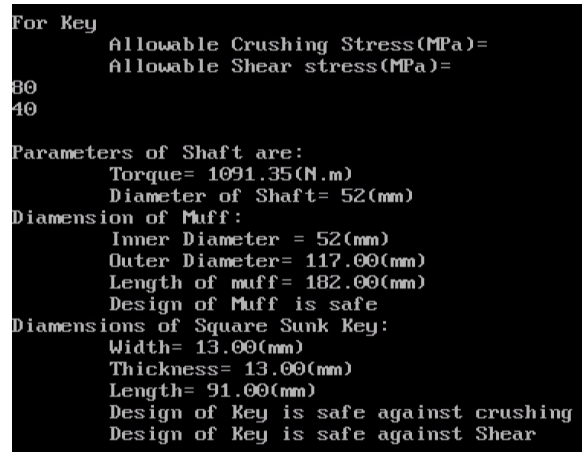
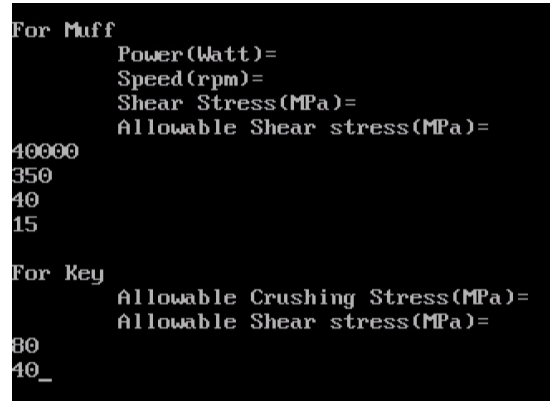

Figure 5 Output on screen

**RESULT**

Dimensional values of parameters are differing due to difference in shaft diameter consideration as shown in Table 1. Design is safe against shear and crushing in both the cases.

**Table 1** Comparison, solution as in reference and output obtained by programming.

Parameter	Solution in reference	Programming output
Shaft Diameter (mm)	52~55	52
Shaft Torque (N. m)	1100 x 10 <sup>3</sup>	1091.35 x 10 <sup>3</sup>
Inner Diameter of Muff (mm)	55	52
Outer Diameter of Muff (mm)	123~125	117
Length of Muff (mm)	192.5~195	182
Thickness of Key (mm)	18	13
Width of Key (mm)	18	13
Length of Key (mm)	97.5	91

```
C:\TurboC4\TC\BIN\MUFF_COUC - Notepad++
File Edit Search View Encoding Language Settings Macro Run Plugins Window ?
C:\TurboC4\TC\BIN\MUFF_COUC
1 #include<stdio.h>
2 #include<conio.h>
3 #include<math.h>
4 #define Pi 3.141593
5 void main()
6 {
7     int d;
8     float P,N,Sc,Sca,Scr,T,D,L,cb,w,t,l, Cr,Cra,SSc,SSca;
9     clrscr();
10    printf ("\nFor Muff\n\tPower(Watt)=\n\tSpeed(rpm)=\n\tShear Stress(MPa)=\n\tAllowable Shear stress(MPa)=\n");
11    scanf ("%f%f%f%f", &P, &N, &Sc, &Sca);
12    printf ("\nFor Key \n\tAllowable Crushing Stress(MPa)=\n\tAllowable Shear stress(MPa)=\n");
13    scanf ("%f%f", &Cra, &SSca);
14    //Design of shaft
15    T = (P*60)/(2*Pi*N);
16    cb = (16*T*1000)/(Pi*Sc);
17    d = pow(cb, (double)1/3);
18    d+=1;
19    printf ("\nParameters of Shaft are:\n\tTorque= %0.2f(N.m)\n\tDiameter of Shaft= %d(mm)", T, d);
20    //Design of Muff (Sleeve)
21    D = 2*d+13;
22    L = 3.5*d;
23    printf ("\nDimension of Muff:\n\tInner Diameter = %d(mm)\n\tOuter Diameter= %0.2f(mm)\n\tLength of muff= %0.2f(mm)", d, D, L);
24    Scr = T*1000 * (16/Pi) * (D/(D*D*D-D*d*d*d));
25    if (Scr<Sca)
26    {printf ("\n\tDesign of Muff is safe");
27    //Design of Key
28    w=d/4;
29    t=d/4;
30    l=L/2;
31    printf ("\nDimensions of Square Sunk Key:\n\tWidth= %0.2f(mm)\n\tThickness= %0.2f(mm)\n\tLength= %0.2f(mm)", w, t, l);
32    Cr = T*1000*4 / (l*d*t);
33    if (Cr<Cra)
34    {printf ("\n\tDesign of Key is safe against crushing");
35    SSc =T*1000*2 / (l*w*d);
36    if (SSc<SSca)
37    {printf ("\n\tDesign of Key is safe against Shear");
38    }
39    else
40    printf ("\n\tDesign of Key is Unsafe against Shear");
41    }
42    else
43    printf ("\n\tDesign of Key is Unsafe against crushing");
44    }
45    else
46    printf ("\n\tDesign of Muff is Unsafe");
47    getch();
48 }
```

Figure 4 Program draft

## CONCLUSION

Thus Source code for designing muff coupling is developed in current work using C-programming. After execution of program on Turbo C the accurate solution is generated in few seconds. Dimensional parameters and stress considerations are compared with standard values. These values are differs from each other due to shaft diameter round up in standard case; but it is found that design is safe against crushing and shear in both the cases: standard as well as by programming. Hence computer tool is introduced here to design machine element like muff coupling

## References

1. <http://www.ignou.ac.in/upload/Unit-6-60.pdf> 154-155.
2. [http://www.dss.nitc.ac.in/ivle6/uploading/fact/134/1739/LNote/Design\\_11\\_c.pdf](http://www.dss.nitc.ac.in/ivle6/uploading/fact/134/1739/LNote/Design_11_c.pdf).
3. [http://www.tutorialspoint.com/cprogramming/cprogramming\\_tutorial.pdf](http://www.tutorialspoint.com/cprogramming/cprogramming_tutorial.pdf).
4. <http://www.rmctet.com/lib/Resources/E-Books/Mech-auto/E-Books%20Machine%20Design-Khurmi%20R.s/CHP-13.pdf>.
5. R S Khurmi and J K Gupta, A Textbook of Machine Design, 14<sup>th</sup> Edition, Eurasia Publishing House: 481, (2005).
6. <http://www.draw.io>.
7. Yashwant P Kanetkar, Let Us C, 8<sup>th</sup> Edition, Infinity Science Press, (2008).

\*\*\*\*\*

### How to cite this article:

Rohan R Ozarkar., Nitin G Shinde and Manish S Sathe.2016, Dimensional Calculations of Muff Coupling By Using C-Programming. *Int J Recent Sci Res.* 7(4), pp. 10468-10471.

T.SSN 0976-3031



9 770976 303009 >